

SEEPEX.
ALL THINGS FLOW

IMPROVED PRODUCTIVITY SCT SMART CONVEYING TECHNOLOGY

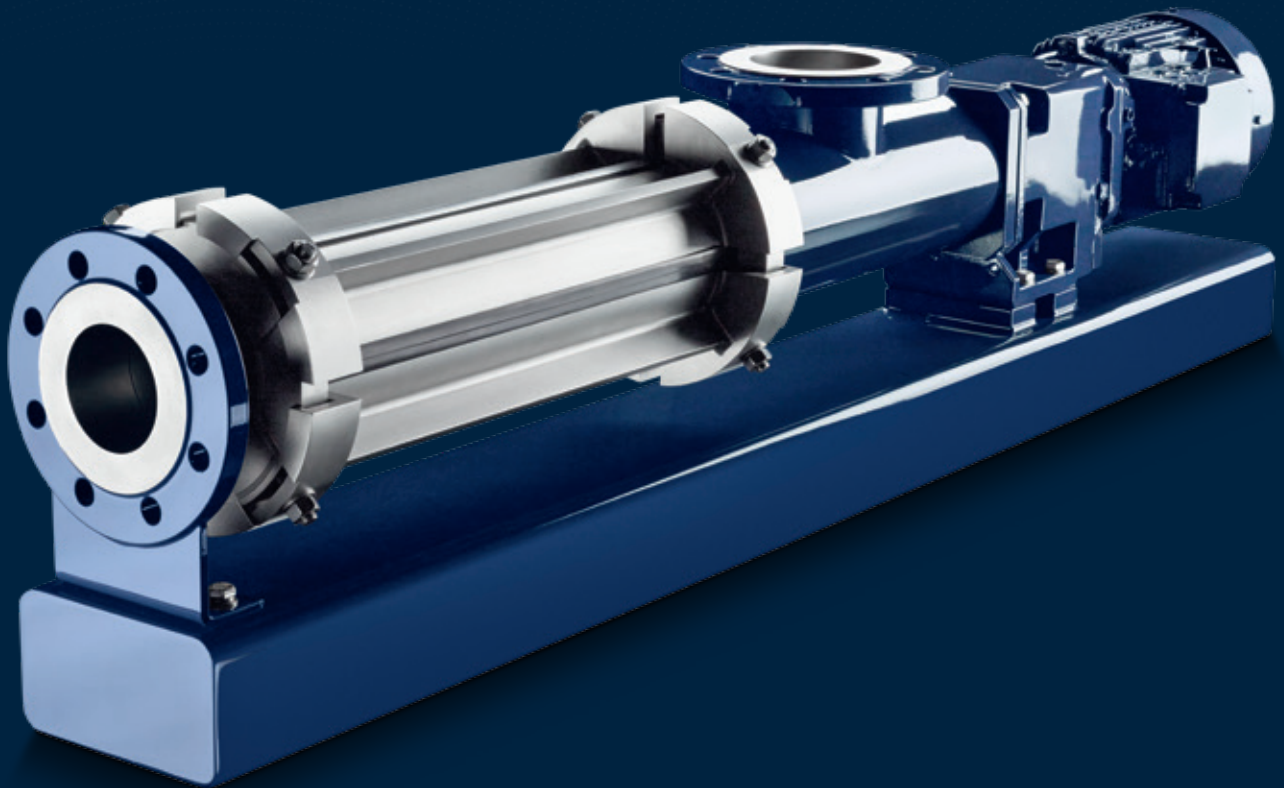

IN A FLASH.

Smart Conveying Technology (SCT) means faster maintenance, shorter downtime and significantly reduced life cycle costs. This unique SEEPEX product has already won several awards and is internationally patented.

The design principle of this smart technology: The Smart Stator is divided into two parts, so that maintenance can easily be done by one person without the need to remove either the suction or discharge pipe work. Additionally, the two piece Smart Rotor allows for quick and easy removal and replacement without the need to dismantle the joint or use special tools, saving time and money. The result: Maintenance in the shortest possible time resulting in less downtime and increased productivity.

Another design feature is the integrated retensioning device, which allows the clamping between the rotor and stator to be adjusted for optimum flow and readjusted when the flow rate reduces due to wear. Readjustment is done in a matter of minutes, returning pump performance to the required level without replacing any components. As such, the service life of both the rotor and stator is significantly extended, removing the need for replacement parts and reducing the life cycle costs of the SEEPEX pump.

Pumps with Smart Conveying Technology (SCT) can also optionally be equipped with a sectioned seal housing. This reduces the maintenance time for the mechanical seal and the drive-side joint to a minimum. In addition, the sectioned housing prevents damage to the mechanical seal on all drive-side work.

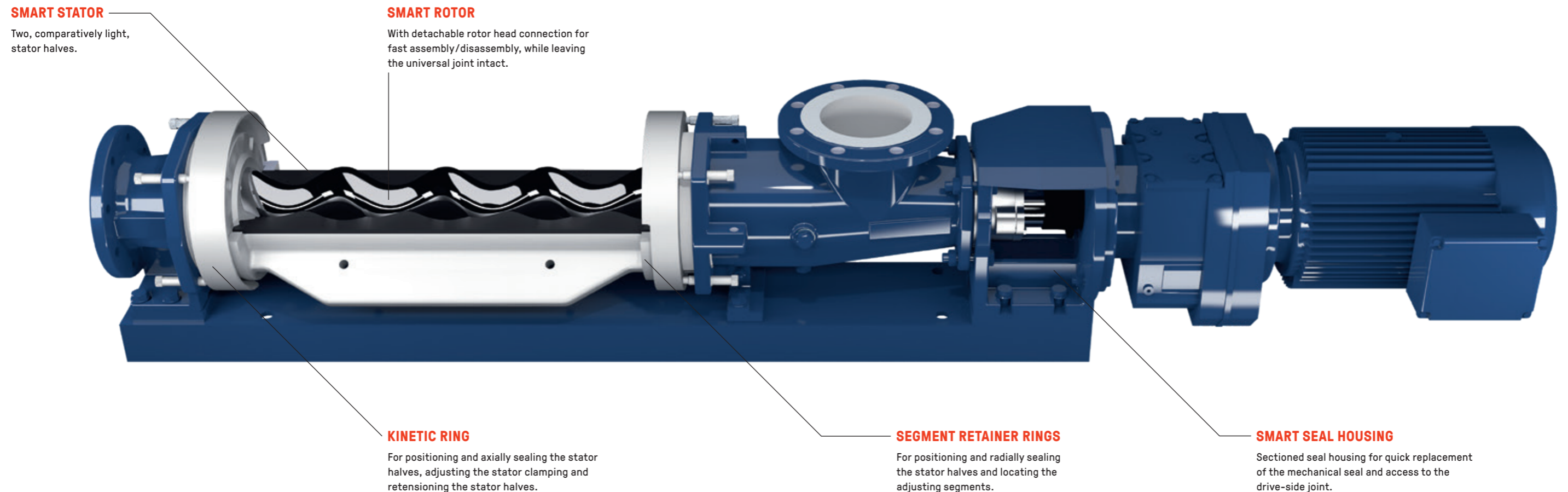

REDUCED LIFE CYCLE COSTS.

Progressive cavity pumps have a long service life, generally expected to be in the region of 15 years. The largest contributors to the total life cycle cost of these pumps are downtime (loss of production), energy and maintenance.

With SCT, you not only extend the life of the pump but also increase efficiency and save on costs. Reduced downtime and the subsequent increase in production are crucial for all industries, and low maintenance costs are important for all pump users. SEEPEX SCT pumps provide a compelling economic solution for all industries.

HOW DO SEEPEX CUSTOMERS BENEFIT FROM SCT?

- Increased productivity, reduced downtime
- Reduction in maintenance time by up to 85%
- Integrated retensioning device resulting in up to 200% increase of rotor and stator life
- Significantly reduced life cycle costs
- Lighter components allowing faster maintenance and assembly/disassembly with minimal manpower
- High efficiency due to lower energy requirements
- Simple maintenance without the need for special tools
- Less space required for installation and essential maintenance as suction and discharge pipework remain in place
- Environmentally friendly as components can easily be recycled

HIGH ENERGY EFFICIENCY

The reduction of energy consumption is a priority for most customers in all industries, but how can savings be implemented?

THE MOST COMMON METHODS FOR SAVING ENERGY:

- Reduction of power requirement
- Replacement of old inefficient equipment with the latest and most efficient technology
- Utilize the most efficient drive technology

Compared to conventional pumps, SCT triumphs with very low energy costs. In a highly competitive market this provides commercial advantages for SCT users. Our SEEPEX experts are knowledgeable about many proven energy efficiency solutions and will survey your site to suggest improvements.

INTERNATIONALLY PATENTED.

Smart Conveying Technology is the result of consistent refinement of the original design called Smart Stator Technology (SST) from 2008. SST was the design and development of a two-piece stator without the usual metallic tube, positioned and sealed together by four individual adjusting segments. This internationally patented innovation has already been successfully installed several thousand times since its invention and launch into the marketplace.

But we didn't stop there: In 2010 SEEPEX further improved the design and developed and incorporated a two-piece rotor that can be replaced easily and quickly while leaving the universal joint intact. The rapid rotor change saves even more time on essential maintenance. Thanks to SCT, maintenance on the rotor and stator is the quickest and most efficient of any supplier.

ENERGY EFFICIENCY

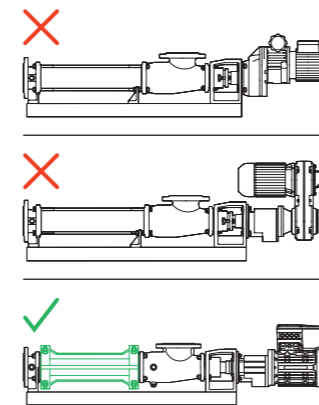
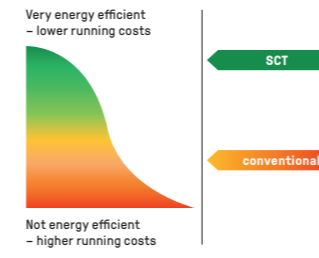

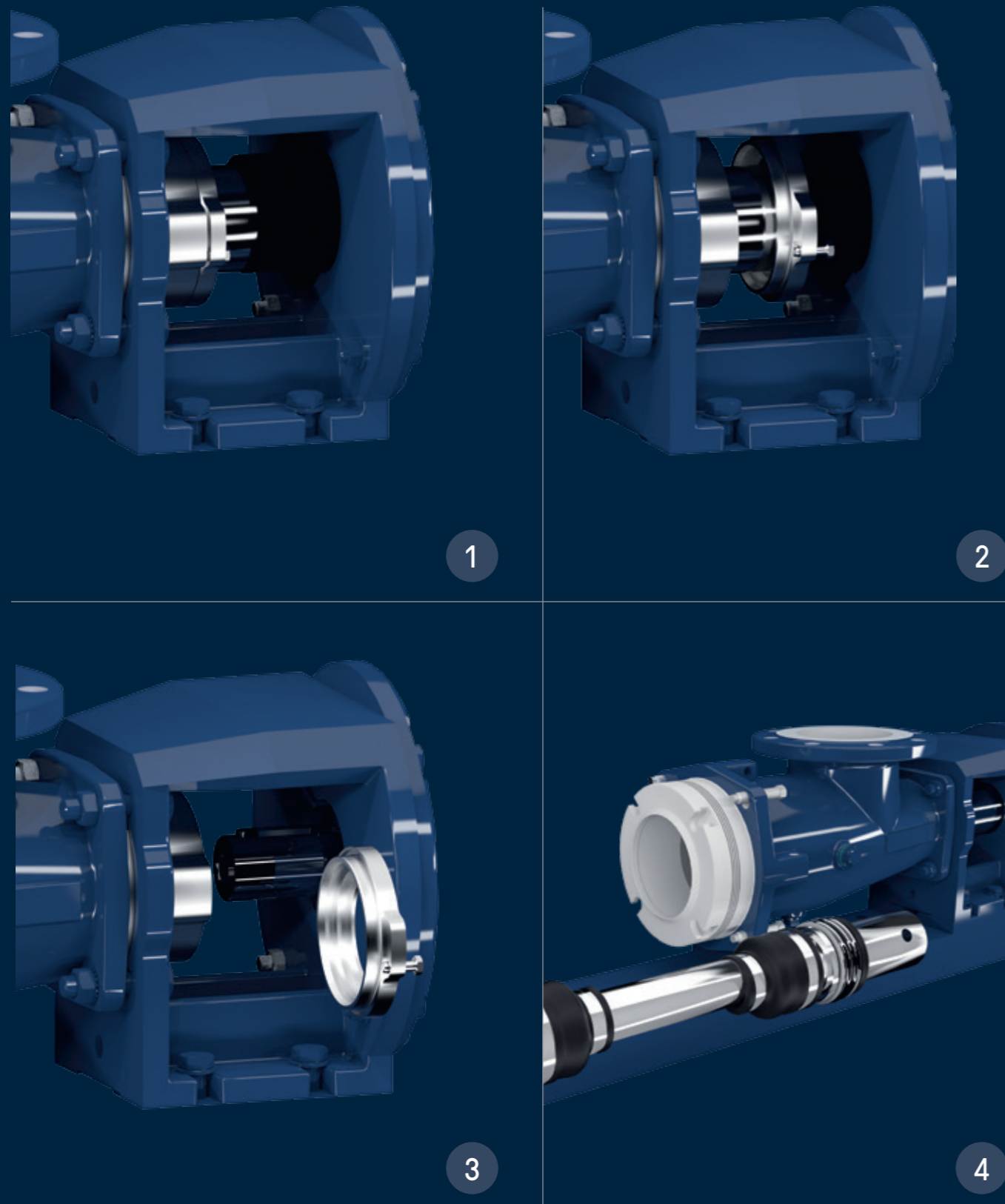

EVEN FASTER MAINTENANCE.

Smart Seal Housing allows you to service drive-end pump components quicker and easier than ever before.

Smart Seal Housing (SSH) is a technical addition to the tried-and-tested Smart Conveying Technology. Previously, when maintenance was required, the suction pipework was disconnected to move the suction casing forward and to gain access to the mechanical seal housing, joints and drive train. SSH enables the complete replacement of the stationary face of the seal by removing it through the pump lantern without the need to dismantle further components. The rotating unit can then be easily withdrawn allowing access to the rotating face of the seal and both universal joints.

Maintenance work is reduced to only a few minutes, resulting in significantly shorter downtime.

FEATURES AND BENEFITS

- Sectioned seal casing
- Quick maintenance and easy replacement of the mechanical seal
- Easy access to the drive-side joint
- No damage to the mechanical seal during drive-side work
- No dismantling of suction casing and piping necessary
- Removal of casing cover with counter ring possible
- Suitable for standard mechanical seals
- Reduced maintenance times and costs
- Patent pending

Smart Seal Housing is optionally available for pumps with Smart Conveying Technology. Our experts will be happy to answer your questions regarding possibilities and benefits.

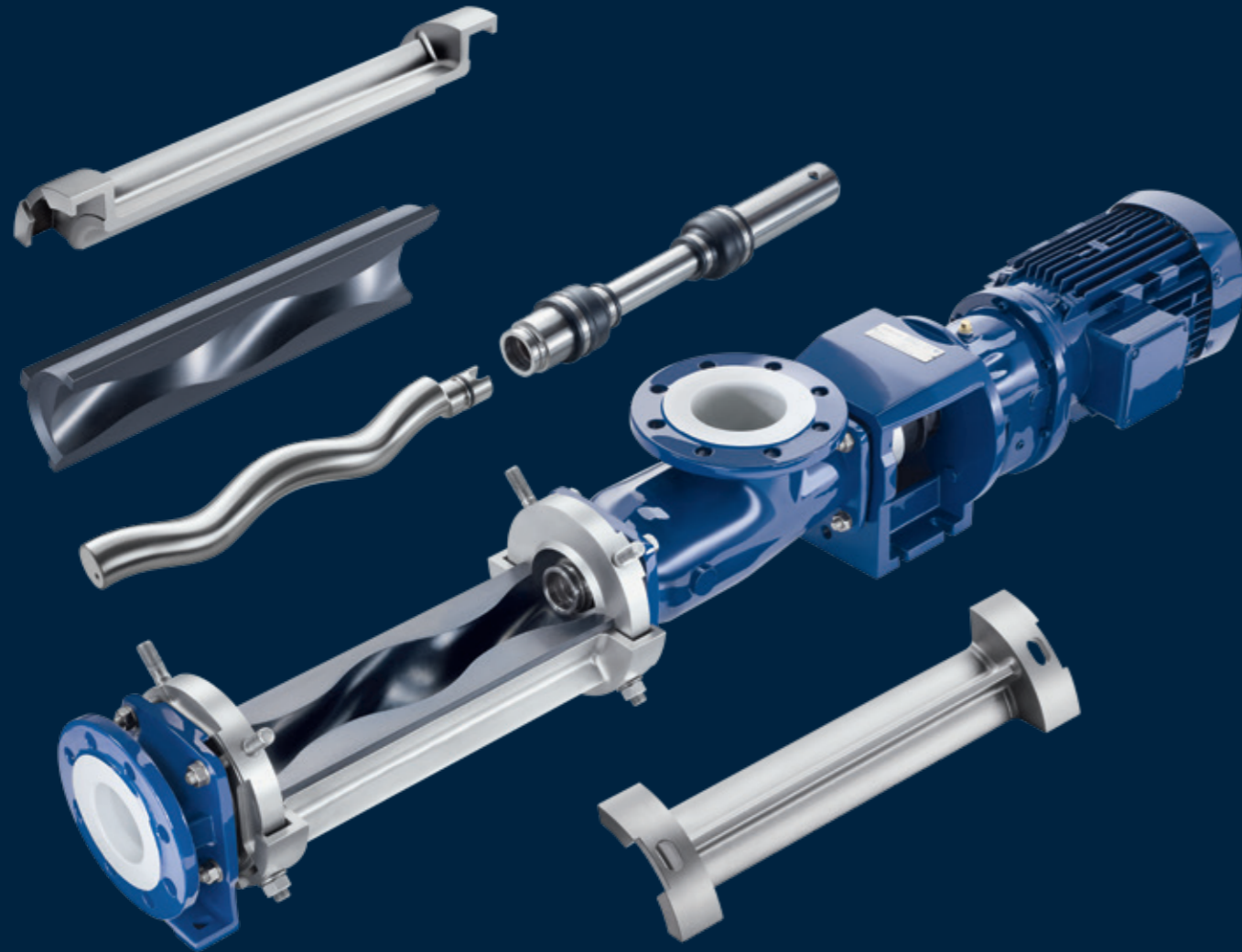

SCT RETROFIT KIT.

There are two ways to take advantage of the many benefits of SCT – either through purchasing a SEEPEX progressive cavity pump with SCT or by upgrading an existing pump with the latest Smart Conveying Technology.

THE SCT RETROFIT KIT INCLUDES:

- Rotor and stator in SCT design
- Universal joint parts
- All relevant castings
- All necessary fasteners to convert your existing pump to SCT

The retrofit kit works with all SCT suitable pumps. Our SEEPEX experts will gladly advise you if your pump can be upgraded.

ONE-PIECE ROTATING UNIT.

The double plug and play design of the rotating unit makes it quick and easy to replace the wearing parts, saving time and money.

- Quick and easy maintenance
- Reduced downtime due to pre-assembled rotating unit
- Constructed to the original pump specifications to ensure compatibility with pumped media

AT HOME IN ALL INDUSTRIES.

SEPEX SCT pumps have been supplied into most industries for a wide variety of applications and products.

SCT IN RENEWABLE ENERGY

In numerous biogas plants, Smart Conveying Technology has shown a clear advantage over conventional progressive cavity pumps and other types of pumping technologies, on a wide range of applications.

SCT has a proven track record and performs efficiently and effectively, providing longer component life and quick and easy maintenance. Subsequently profitability is increased due to higher production levels.

SCT IN ALL INDUSTRIES

SEPEX's Smart Conveying Technology is the perfect solution. SCT allows for simple retensioning of the stator within minutes, meaning the pump can continue to give acceptable flows for longer periods. When essential maintenance is required, both the suction and discharge pipework remain in place resulting in a reduction of maintenance time of approximately 85%.

SCT IN SEPEX APPS

To simplify your pump maintenance our free app – SEPEX VR – is your on-site digital maintenance support. With step-by-step instructions and 3D animations technicians can service SEPEX pumps much easier.

CONTINUOUS INNOVATION.

Our customers know SEPEX represents constant innovation and customer focus. With SCT, we continue to innovate based on our customers' needs. In addition to the well-established 1-stage design for pressures up to 4 bar, SCT is now also available in a 2-stage design for pressures up to 8 bar. Both pump types offer a wide range of features and benefits.

FEATURES AND BENEFITS

- Two individual rubber stator halves
- Smart Rotor with quick release geometry
- Rotor and stator compression can be adjusted to suit the application
- Readjustable when wear occurs
- No special tools are required
- Built-in lifting aids (2-stage)
- Double plug and play power train
- Reduced risk of ragging
- Patented solution

PRESSURE, 1-STAGE
**UP TO 4 BAR
(60 PSI)**

PRESSURE, 2-STAGE
**UP TO 8 BAR
(120 PSI)**

1-STAGE

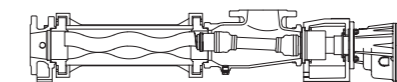

2-STAGE

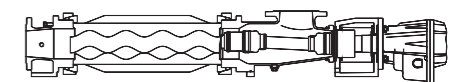

SEEPEX.
ALL THINGS FLOW

SEEPEX GmbH
www.seepex.com