

# Air and Dirt Separator

2  
ΧΡΟΝΙΑ  
Εγγύηση

Απαερωτές & Διαχωριστές Σωματιδίων  
για απομάκρυνση αέρα και  
σωματιδίων στα κλειστά  
κυκλώματα θέρμανσης & ψύξης



Εφαρμογές σε κλειστά κυκλώματα θέρμανσης,  
ψύξης & ενδοδαπέδιας θέρμανσης

Προϊόν χαμηλής συντήρησης

Υψηλή ποιότητα κατασκευής από ανθρακούχο  
χάλυβα με βαφή πούδρας

Συνδέσεις φλάντζας  
DN 2", 2½", 3", 4", 5", 6" & 8" – PN16

Ονομαστική πίεση λειτουργίας 10 bar

Περιγραφή	Κωδικός	Τιμή (€)
<b>2.0" AIR &amp; DIRT SEPARATOR</b>	FL1-03-04295-EU	<b>1.728</b>
<b>2.5" AIR &amp; DIRT SEPARATOR</b>	FL1-03-04296-EU	<b>1.756</b>
<b>3.0" AIR &amp; DIRT SEPARATOR</b>	FL1-03-04297-EU	<b>2.365</b>
<b>4.0" AIR &amp; DIRT SEPARATOR</b>	FL1-03-04298-EU	<b>2.461</b>
<b>5.0" AIR &amp; DIRT SEPARATOR</b>	FL1-03-04299-EU	<b>4.259</b>
<b>6.0" AIR &amp; DIRT SEPARATOR</b>	FL1-03-04300-EU	<b>4.591</b>
<b>8.0" AIR &amp; DIRT SEPARATOR</b>	FL1-03-04301-EU	<b>6.969</b>

## Τεχνικές προδιαγραφές

Air & Dirt Separator							
Product code	FL1-03-04295	FL1-03-04296	FL1-03-04297	FL1-03-04298	FL1-03-04299	FL1-03-04300	FL1-03-04301
<b>Material specification</b>							
Fittings	Carbon Steel PN16 Flanges						
Body	Carbon steel						
Valves	Brass						
Finish	Powder coated RAL5005						
<b>Design specification</b>							
Maximum working pressure	10Bar						
Maximum operating temperature	99°C						
Minimum operating temperature	0°C						
Weight (Kg)	20	21	35	38	63	79	103

### DN50 2"

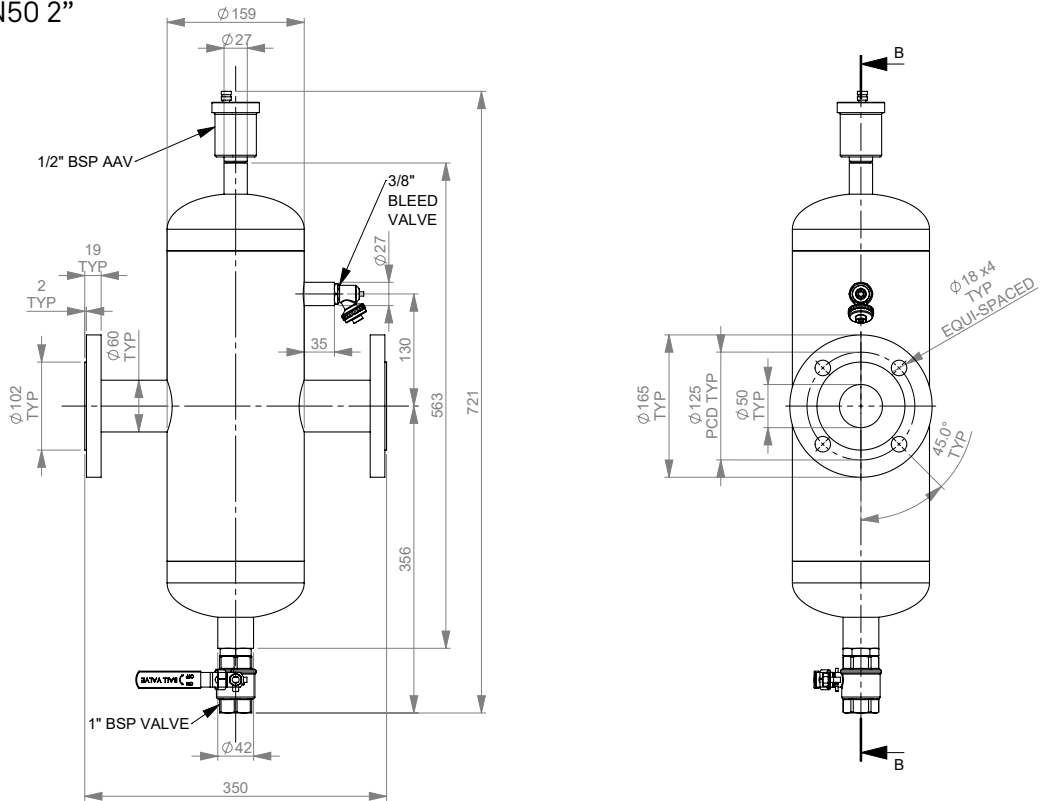

### DN65 2.5"

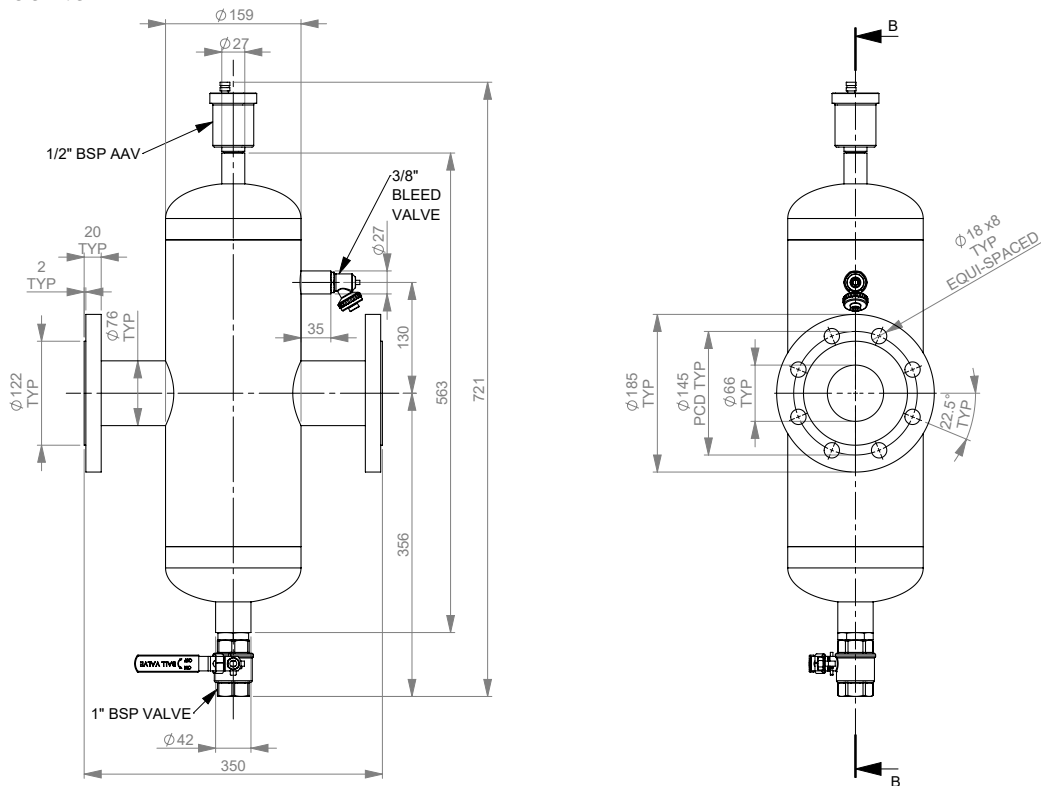

Size	DN50/2"	DN65/2.5"	DN80/3"	DN100/4"	DN125/5"	DN150/6"	DN200/8"
Volume (L)	9	10	24	25	73	75	166
H (mm)	721	721	893	899	1145	1145	1487
W (mm)	350	350	470	475	635	635	775
Weight (Kg)	20	21	35	38	63	79	103



DN125 5"

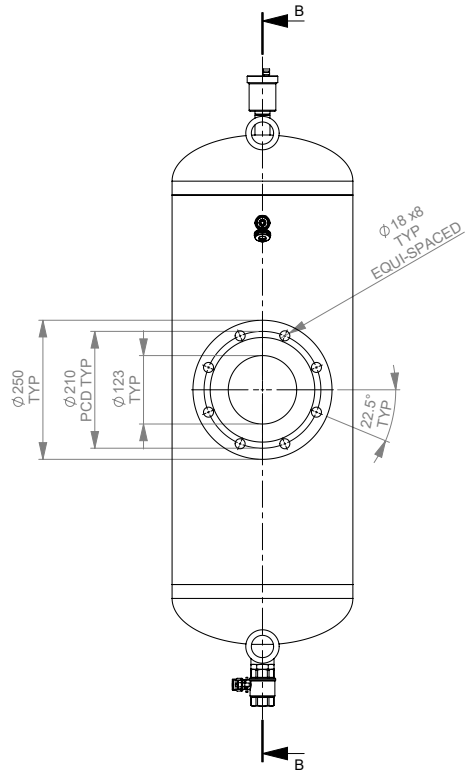
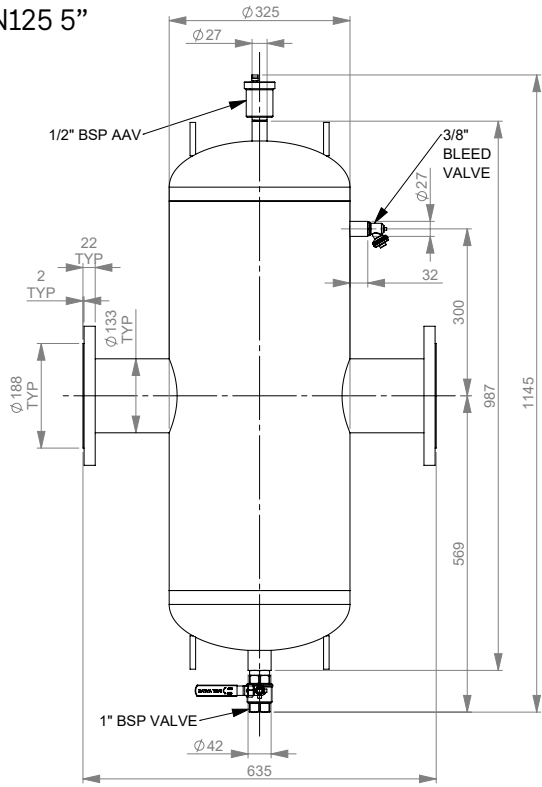

DN150 6"

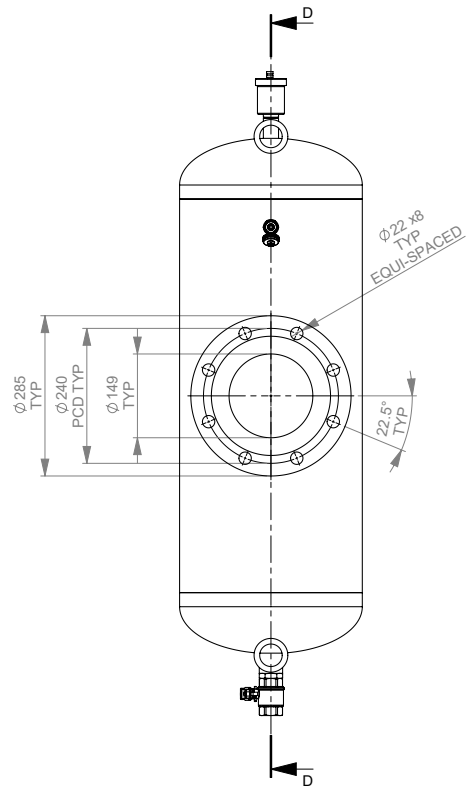
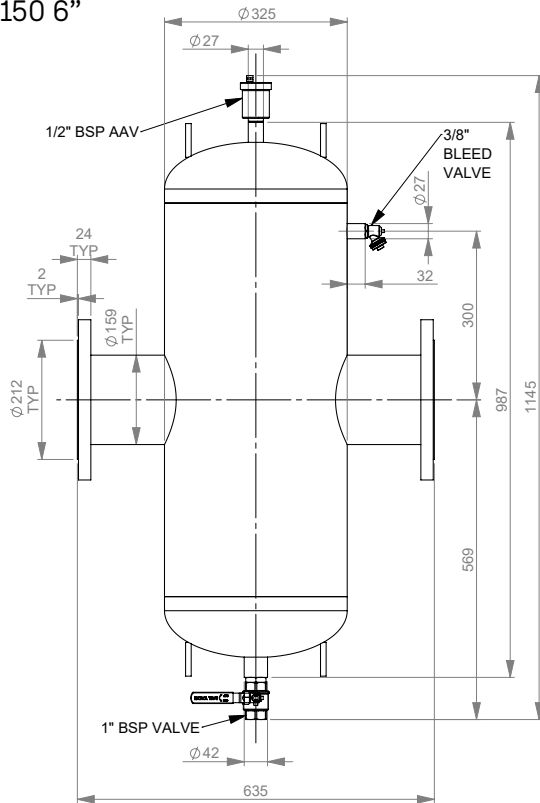

DN200 8"

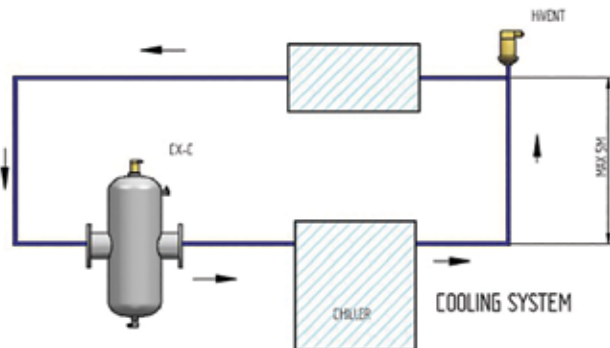
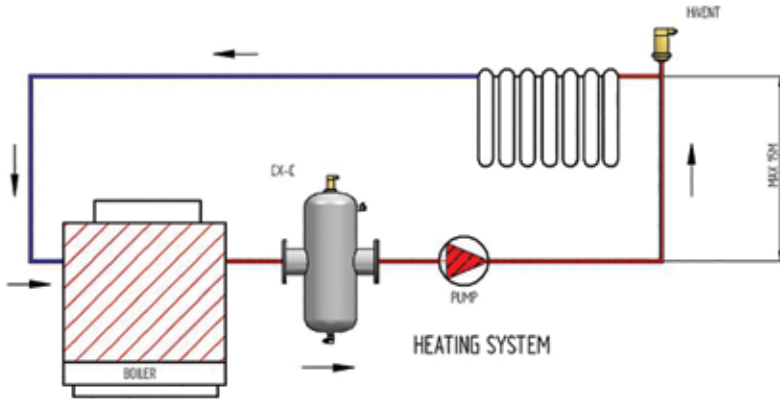
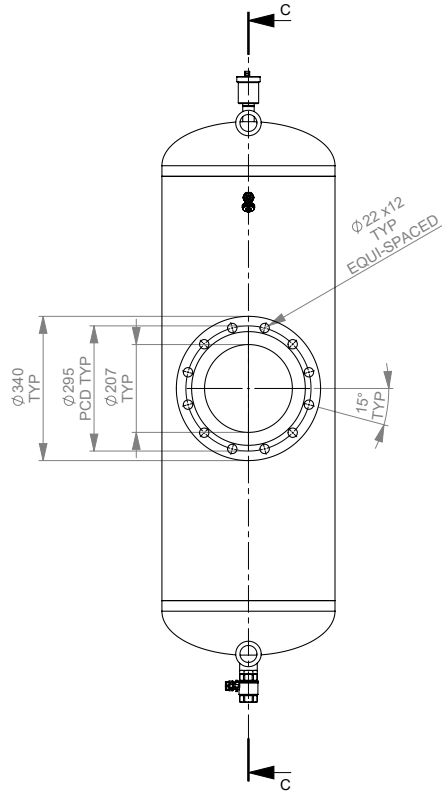
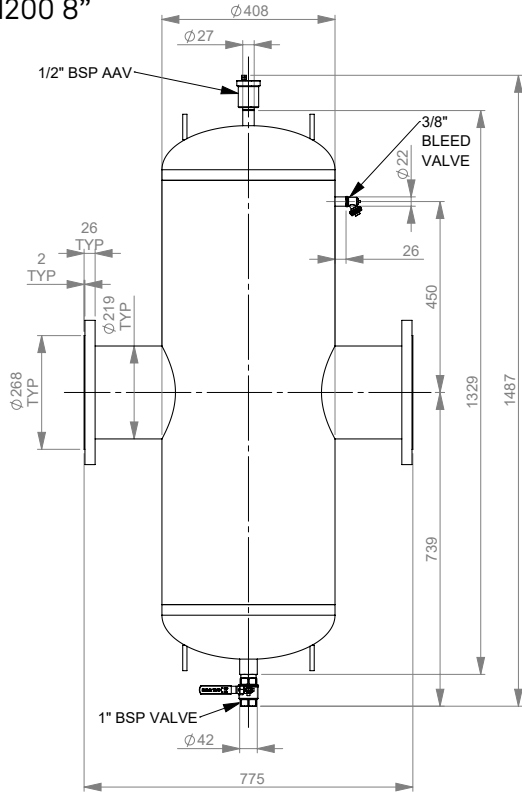

# Διαγράμματα Πτώσης Πίεσης Απαερωτών & Διαχωριστών Σωματιδίων

